

# **MASA**

## **ADJUSTABLE SHOCK ABSORBER**

### **Adjustment Instructions**

**EFDYN, INC.**

**7734 E. 11<sup>TH</sup> ST.**

**(918) 838-1170**

**TULSA, OK 74112**

**FAX (918) 835-3334**

**WWW.EFDYN.COM**

**EFDYN CORPORATION**  
**MASA-1, MASA-2, and MASA-4 Shock Absorbers**

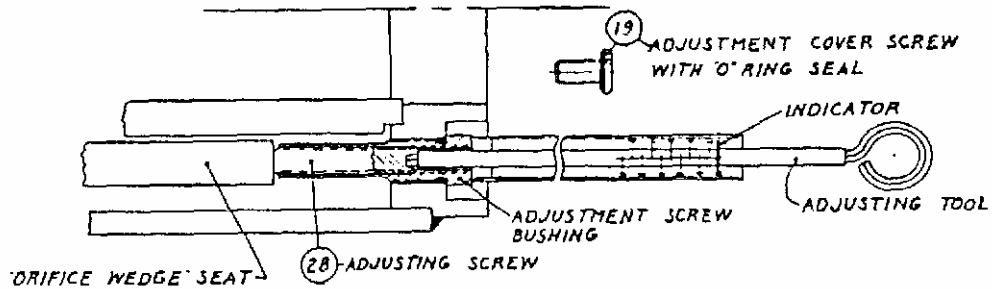

The adjustment screw (Part No. 28 – See Drawing 5-3340-0-01) is positioned against a precision-ground hardened orifice wedge seat that moves axially to open or close the orifices simultaneously as the adjustment screw is rotated. Turning the adjustment screw clockwise opens the orifices and decreases unit resistance, whereas, turning the adjustment screw counter clockwise closes the orifices and increases unit resistance.

An easy to use tool is available for setting or determining the adjustment setting. The tool consists of a specially formed hex key with affixed disc type indicator housed in a graduated plastic tube. The tube graduations have been calibrated to indicate turns of the adjustment screw, each turn being a complete revolution or 360-degrees of rotation. The scale divisions, numbered from zero to twenty, indicate the range of adjustment turns. Since scale readings are directly related to metering orifice size, Zero indicates total shut off and should only be used as a setting reference.

By removing the adjustment cover screw (Part No. 19) and placing the calibrated tube firmly against the adjusting screw bushing, inserting the hex key to fully engage the coaxial adjustment screw as shown on Drawing 5-3340-0-01, the turn setting can be readily obtained by reading the calibrated scale on the plastic tube housing, using the red disc indicator as the setting index. Since the degree of setting accuracy is dependent upon tool engagement depth, care should be taken to properly position the adjusting tool as described when setting or determining adjustment setting.

The range of adjustment turns varies with shock absorber bore size as follows:

|                 |          |
|-----------------|----------|
| MASA-1          | 15 Turns |
| MASA-2 & MASA-4 | 20 Turns |

Making the Adjustment (It is assumed the shock absorber has been properly sized for the load conditions).

1. Remove adjustment cover screw (Part No. 19) completely from adjusting screw bushing. CAUTION – The adjustment cover screw should not be removed when the shock absorber is in operation or when there is standing air pressure on shock absorber as oil will be forced past the threads of the adjustment screw.
2. Insert adjusting tool key into adjusting screw bushing and engage coaxial adjustment screw. Holding the calibrated tube firmly against adjusting screw bushing, rotate the adjusting key clockwise or counterclockwise to obtain required adjustment setting.
3. Remove adjustment tool. The adjustment setting is automatically locked in position by a compression type friction lock.
4. Replace adjustment cover screw and tighten adequately to seat “O” ring seal.

When load conditions (total weight of moving load, velocity of moving load at impact, external driving force) are known, the adjustment turn settings can be obtained by using Efdyn’s Load Setting Nomograph MASA-LS. Since calculated load conditions are generally approximate and frequently vary from actual load conditions, experimental adjustment may be required to obtain optimum performance.

When load conditions are not known, even to some approximation, the following adjustment setting procedure is recommended.

1. Estimate maximum velocity of moving load –  $V \text{ max.} = 2d/t \text{ f.p.s.}$  where  $d$  is the distance the load travels in feet and  $t$  is the time required in seconds to travel this distance. (A stopwatch is recommended.)
2. Determine maximum stopping force based on capacity rating of unit selected. For a 2 inch bore by 6 inch stroke shock absorber (see working capacity ratings in Efdyn Catalog)

$$F \text{ max} = 141,000/6 = 23,500 \text{ lbs.}$$

3. Using Efdyn’s Load Setting Nomograph, determine adjustment turn setting.

This setting will provide the maximum stopping force that can safely be used within the working capacity rating of the unit selected. If load stops too abruptly at onset of impact, reduce stopping force by turning

The adjustment screw clockwise in half-turn increments until load comes to rest smoothly, full shock absorber working stroke being utilized. Optimum adjustment will allow piston rod to travel full working stroke with minimum metal-to-metal contact between back face of bumper cap and front head of shock absorber.

If the load appears to move thru the shock absorber without resistance, and metal-to-metal contact between bumper cap and front head of shock absorber is hard, or load appears to stop too abruptly just prior to post travel, increase resistance by turning the adjustment screw counter-clockwise in half-turn increments until load comes to rest smoothly. CAUTION – If the shock absorber has initially been set to provide maximum resistance as described above, and load appears to move thru without resistance, consult factory. The unit selected may be undersized or different orifices may be required.

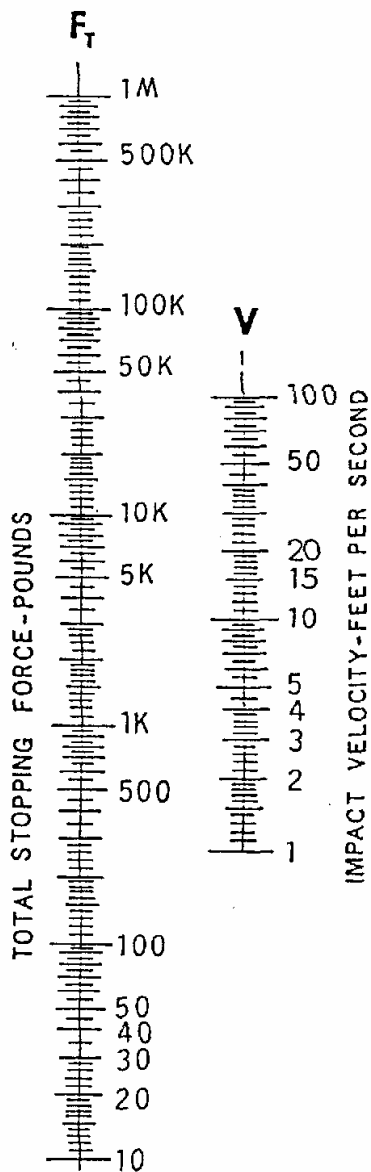

X  
REFERENCE LINE

## MODEL MASA ADJUSTABLE SHOCK ABSORBER LOAD SETTING NOMOGRAPH

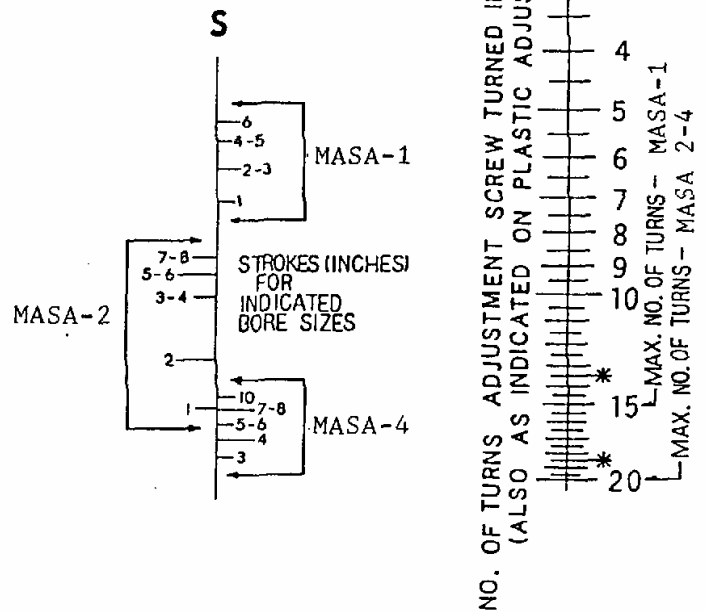

This nomograph determines the proper adjustment setting for EFDYN Model MASA Adjustable Shock Absorbers. To use it, first obtain the total stopping force and impact velocity for shock absorber. Refer to the MASA catalog load data to make sure that the design load does not exceed the capacity of the unit selected. Next draw a line from the required stopping force on scale  $F_T$  and through the impact velocity point on Scale  $V$  to reference line  $X$ . Next determine the point on scale  $S$  which represents the model and stroke of shock absorber to be used. (Note that MASA-1, MASA-2 etc. represent the nominal bore size of EFDYN Adjustable Shock Absorbers. The stroke length of the shock absorber is listed within the bore diameter brackets.) Draw a line through this point and the previously established intersection on reference line  $X$  to Scale  $N$ , which gives the number of turns the adjustment screw should be turned in (clockwise) from the fully closed position of the adjustment.

The number of turns indicated on scale  $N$  can also be read directly from the scale on the plastic sleeve of the adjusting key tool provided for use with EFDYN MASA Shock Absorbers.

When the adjustment turn setting determined from the nomograph is less than  $1\frac{1}{2}$  or more than  $13\frac{1}{2}$  for model MASA-1 and less than  $1\frac{1}{2}$  or more than  $18\frac{1}{2}$  for Models MASA-2 & 4, select a unit with either a longer or shorter stroke to obtain a turn setting within above limits. If this is not possible or desirable, consult EFDYN Engineering Dept. for optional orifice sizing.