

# **MASA**

## **ADJUSTABLE SHOCK ABSORBER**

### **INSTALLATION, OPERATION, & SERVICE INSTRUCTIONS**

**EFDYN, INC.**

**7734 E. 11<sup>TH</sup> ST.**

**(918) 838-1170**

**TULSA, OK 74112**

**FAX (918) 835-3334**

**WWW.EFDYN.COM**

## TABLE OF CONTENTS

### INSTALLATION, OPERATION AND SERVICE INSTRUCTIONS EFDYN MODEL MASA SHOCK ABSORBER

---

	<u>Page</u>
I. General Instructions	1
A. Surface Finish.....	1
B. Nameplate – Model Number.....	1-2
C. Serial Number.....	2
D. Load Rating.....	2
E. Fluid Filling.....	2
II. Installation	2
A. Mounting Attitude	2-3
B. Mounting Support	3
C. Protecting Piston Rod	3
D. Special Safety Measures	3
E. Accumulator Mounting	3-4
III. Hydraulic Fluids	4
A. Efdyn Dynoil “A-1”	4
B. Efdyn Dynoil “H”	4-5
C. Fire Resistant Fluids	5
D. Silicone Fluids	5
IV. Oil Filling	5
A. Filling Spring Return Models	5-6
B. Filling Air Return Models (Single Line System)	6-7
C. Filling Air Return Models (Recirculating System)	7-8
V. Operation	8
A. Uniform Deceleration	8-9
B. Operating Temperatures	9
C. Other Factors Influencing Successful Operation	9
VI. Maintenance	9
A. Oil Replacement	10
B. Parts Replacement	10-11
C. Reference Drawings	12
VII. Adjustment Setting Instructions	12
VIII. Parts Drawings	12

I. General Instructions

Efdyn shock absorbers are reliable units designed to cushion a moving load to the most gentle stop possible. They are ruggedly built and will perform for many years of trouble free service provided adequate maintenance procedures are followed.

A. Surface Finish

All standard shock absorbers are painted Efdyn Blue per Efdyn Spec. #1-3238-0-01. THE PISTON ROD SHOULD NEVER BE PAINTED.

B. Nameplate

The nameplate gives pertinent information regarding the unit. The model number designation is coded as shown in the chart below.

<u>Subject</u>	<u>Type</u>	<u>Designation</u>	<u>Example Model Number</u>
Model	Adjustable	MASA	MASAS-2-4-HRS-99
Rod Extension	Standard Foundry (1/2) Foundry (2)	S F T	
Bore		1 1/8 2 4	
Stroke		Specified	
Mounting Style	Primary Front Flange Back Flange Foot Lug Side Lug Rear Hinge Rod Eye	P F B L S H R	
Rod Return Method	Spring Air	S A	
Modifications		*	

\* Standard units show designation 99 to indicate they are not modified. When unit is special, appropriate modification number(s) is shown. Consult factory for modification coding explanation.

‡ Foundry models are identical to standard models except for a one-half-inch or two-inch rod extension which aids in preventing sand from being pounded into rod wiper by the bumper cap.

1. Spring return models incorporate an internal spring (s) which returns the piston rod to the outward position with sufficient force to overcome friction. Do not rely on the spring force to return outside members which might be part of the moving load. Spring forces are as follows:

<u>Bore</u>	<u>Rod Extended</u>	<u>Rod Retracted</u>
1 1/8	18 lbs.	36 lbs.
2	48 lbs.	96 lbs.
4	100 lbs.	200 lbs.

2. Air return models require an external air over oil accumulator which is usually connected to a compressed air source. The pressurized oil acts on the rod area of the piston rod to return it to the outward position with shop line air at 80 to 125 P.S.I. Higher duty cycle rates than with spring return models may be realized since the air return method is capable of radiating more heat when connected as a recirculating system. It also provides a greater oil supply reserve and may be programmed to delay the rod return until completion of a subsequent operation. Do not attach air line directly to shock absorber.

C. Serial Number

Every unit manufactured by Efdyn is assigned a serial number. It is stamped on the unit and also the nameplate. This number should always be given when ordering a unit for an identical application or spare parts.

D. Load Rating

Each shock absorber has a maximum stopping force rating which should not be exceeded. Refer to Catalog Bulletin No. MASA-77.

E. Fluid Filling

Air return shock absorbers are shipped dry. Spring return shock absorbers are shipped filled with oil unless special conditions dictate otherwise. (See Filling Instructions, Section IV.)

II. Installation

A. Mounting Attitude

1. Standard self-contained (spring return) shock absorbers may be mounted horizontally or vertically with piston rod up. If a unit has been specified to operate at an angle of more than five degrees either side of horizontal or vertical centerline, bleeder screws will have been relocated accordingly before shipment.

However, if an accumulator is used, a standard shock absorber may be mounted at any angle.

B. Mounting Support

1. Supporting structure must be rigid and so constructed that deflection under full stopping force is negligible.
2. The moving load must be well guided and in line with shock absorber at point of impact. If it is subject to lateral wandering, side forces may be imposed on the piston rod resulting in excessive bearing wear. The bumper cap is hardened to 45-50 Rockwell C. If the contacting surface on the load is soft in comparison to the cap, a depression may be formed which could trap the bumper cap if the load shifts and result in a bent rod. To avoid this, attach a hardened plate at point of impact on moving load.

C. Protecting Piston Rod

1. Trouble free performance depends largely on smooth functioning of the piston rod. Utmost care should be taken during installation and operation to prevent bending, denting, scratching, or gouging.

D. Special Safety Measures

1. Mounting screws should be of high strength alloy steel.
2. External mechanical stops are recommended for the load, set to contact just before the bumper cap on the piston rod strikes the shock absorber front head. This added protection is desirable in the event that low oil level, improper adjustment or overload might cause bumper cap to impinge against front head with possible distortion of gland retaining ring groove.
3. Back up bar, keyed or welded to base, should be used at rear of lug mounted models.
4. Try out the load initially at slow speed after it has been mounted and filled to test for proper operation.

E. Accumulator Mounting

An accumulator is required on all air return models and may also be used on spring return models to provide an ample supply of make-up oil to replace that lost during a long period of time during normal operation.

1. Standard accumulators should always be mounted above the shock absorber.

2. Hydraulic lines from the shock absorber to the accumulator should have an inside diameter equal to or larger than that indicated by the filler port thread.
3. If phosphate ester fluids are to be used, hose material should be compatible.

### III. Hydraulic Fluids

#### A. Efdyn "Dynoil A-1"

All standard spring return shock absorbers are normally filled with this fluid before shipment. This hydraulic fluid is especially compounded to rigid Efdyn specifications. It has a lower viscosity and a lower pour point than Efdyn "Dynoil H". It is recommended where shock absorbers are to be used outdoors and applications where impact occurs infrequently and heat build-up is insignificant. It is primarily used at lower ambient temperatures. Viscosity is 195 SSU at 100°F.

Other suitable fluids with characteristics similar to Efdyn "Dynoil A-1" are shown in the partial list below.\*

<u>Brand</u>	<u>Product</u>
Cities Service	Pacemaker 20
Gulf	Harmony 47
Mobil	DTE Medium
Pure Oil	Puropale RX Medium
Shell	Tellus 29
Standard	American Industrial 25
Texaco	Regal "B" R & O
Fisher Body (Spec.)	WEL-03 & WEL-34

#### B. Efdyn "Dynoil H"

This hydraulic fluid is also especially compounded (made with straight cut solvent refined neutral oils) to rigid Efdyn specifications and is strongly recommended for rapid cycle and indoor use. However, other high quality petroleum base oils with a high aniline point, anti-foaming and oxidation additives may be used. Viscosity range should be 500-600 SSU at 100°F.

Other suitable fluids with characteristics similar to Efdyn "Dynoil H" are shown in the partial list below.\*

<u>Brand</u>	<u>Product</u>
Pure Oil	Puropale RX 4193
Gulf	Gulf Harmony 54 AW
Mobil	DTE Extra Heavy
Texaco	Regal "P" RXO or Rando "F"
American	Amer. Industrial 51 or Rykon 51
Fisher Body (Spec.)	WEL-10
Citgo	Pacemaker 60

\*Mixing petroleum base oils of different brands is not recommended for shock absorbers use. Flush system with a suitable solvent when changing from one brand to another.

C. Fire Resistant Fluids

If this type fluid is required, a few suitable brands are mentioned below. Special rod packings must be used.

<u>Brand</u>	<u>Product</u>
Monsanto	Pydraul A-200
E. F. Houghton	Houghto-Safe 1120
E. F. Houghton	Houghto-Safe 1055
Celanese	Cellulube 220

D. Silicone Fluids

Standard shock absorber packings are compatible with these fluids.

<u>Brand</u>	<u>Product</u>
General Electric	Versilube S-50
Dow Corning	DC-200

IV. Oil Filling

A. Filling Spring Return Units: These are normally self-contained, and need no external connections. After mounting, proceed as follows:

1. On horizontally mounted models with filler port at the top of the unit, proceed as follows:
  - a. Remove filler port plug.
  - b. Remove bleeder screw (#35). (This screw is located on left-hand side of unit facing rod.)
  - c. Slowly introduce suitable oil into the filler port, at the same time pushing the piston rod of the shock absorber in and out, until a steady flow of oil; without air bubbles; emerges from the bleed screw hole.
  - d. Replace the filler port plug and bleed screw, and push the piston rod in an additional dozen or so times.
  - e. Remove the bleed screw and recheck the oil level, adding more oil if necessary. Replace the bleed screw and filler port plug.
  - f. Be sure that the piston rod can be pushed all the way in by hand. Over-filling can cause rupture of the outer jacket tube.

2. On horizontally mounted models with filler port at right hand of unit, proceed as follows:
    - a. Remove filler port plug.
    - b. Remove bleeder screw (#35). (Adjacent to filler port.)
    - c. Screw a street "el" with threads to match in filler port for easier filling.
    - d. Proceed as in c, d, e, and f above.
  3. On vertically mounted units with the piston rod up:
    - a. Remove filler port plug.
    - b. Screw a street "el" with threads to match in filler port for easier filling.
    - c. Slowly pour oil into "el" opening, at the same time pushing the piston rod in and out until the oil level reaches the mid-point of the "el" and let excess oil drain out to lower side of filler port.
    - d. Shock absorber will be over-filled at this point. Remove street "el" and let excess oil drain out to lower side of filler port.
    - e. Replace filler port plug.
  4. Vertically mounted units with piston rod down. (Filler port must be positioned at top and piston rod fully extended.)
    - a. Remove filler port plugs.
    - b. Screw a 90° street "el" opening until level reaches lower side of filler port threads.
    - c. Pour oil into "el" opening until level reaches lower side of filler port threads.
    - d. Remove "el" and replace filler port plug and pour oil into hi-pressure port until completely full and replace hi-pressure plug.
    - e. Push the piston rod in a dozen times or so, remove the fill port plugs and recheck the oil level and adding more oil if necessary.
    - f. Replace filler port plugs.
- B. Air Return Models: (Single Line System) Filling normally is accomplished through the filling port of the accumulator, as outlined below. It is important that the interconnecting line be at least as large as the shock absorber port size, and be kept as short as possible.

1. Disconnect air line form accumulator (shop line air pressure).
2. Remove top bleeder screw (and high-pressure port plug on rod down units) from shock absorber.
3. Remove accumulator fill port plug.
4. Pour oil into the fill port of the accumulator while moving the piston rod in and out until all air is purged from the shock absorber as it flows from the bleed hole (and high-pressure port).
5. Replace bleeder screw (and high-pressure plug).
6. Continue to pour oil into the accumulator until it reaches the halfway point on the oil level sight gauge. Push piston rod in a few times to help purge any trapped air from connecting line. Recheck oil level.
7. Replace accumulator fill port plug and reconnect air line.

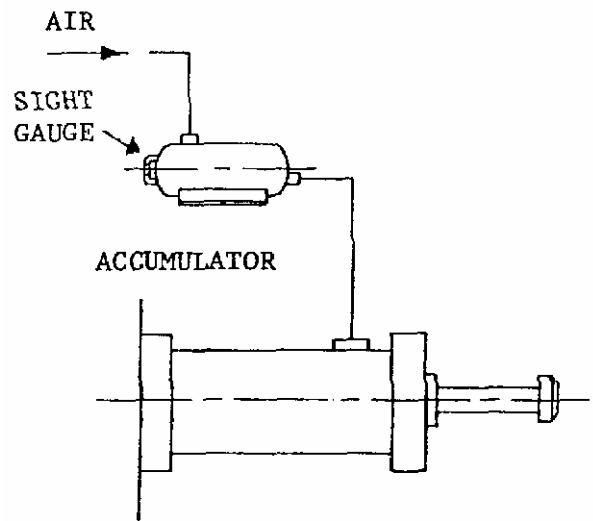

Figure 1

C. Air Return Models: (Recirculating System – Double Line)

It is recommended that shock absorber be completely filled before connecting hydraulic lines. Check valves should be heavy duty type with 5 P.S.I. maximum required to unseat poppet and same size as pipe used.

1. Connect air and hydraulic lines as shown in Figure 2. Make sure check valves are installed in opposite directions for positive oil flow. Check valve with free flow to accumulator port. This line carries fluid resulting from piston rod displacement when impacted and should be as large a diameter as practical in order to minimize fluid transfer velocity and corresponding jacket tube pressure. Install check valves close as possible to shock absorber.

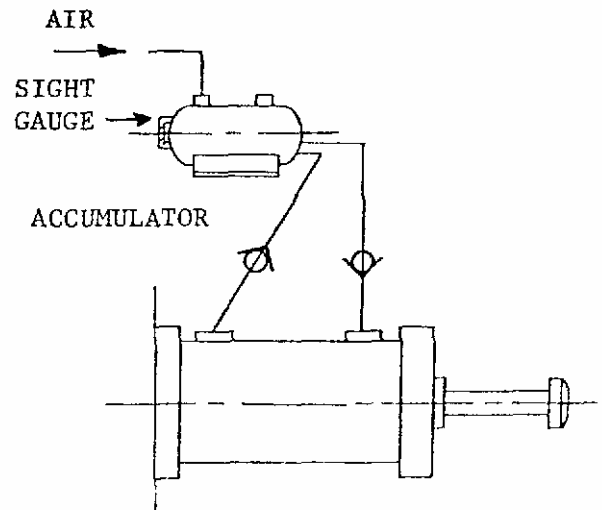

Figure 2

2. Remove top bleeder screw from top side of shock absorber (and high-pressure plug on rod down units).
3. Add oil at accumulator fill port. Oil will flow through the lines down to the check valves. However, there may not be sufficient "head" of oil to unseat the poppet of the check valve allowing oil to enter the shock absorber.
4. Replace accumulator fill port plug.
5. Using a pressure regulator, feed 2 to 5 P.S.I. air at air connection of accumulator to force oil into shock absorber until oil flows from the bleed hole (and high-pressure port on rod down units).
6. Disconnect air line.
7. Replace bleeder screws and high-pressure port plug in shock absorber.
8. Refill accumulator to halfway mark on level sight gauge and replace filler port plug.
9. Reconnect air line, increasing pressure to 80 P.S.I.
10. Operate shock absorber a few times and recheck oil level. Add oil as required.

## V. Operation

- A. Uniform Deceleration: This principle governing the operation of Efdyn shock absorbers provides the gentlest possible cushioning throughout the complete stopping range. The precision orifices, specifically engineered and designed for load rating of each shock absorber, ensure optimum performance.
  1. Velocity: If the load to be stopped has no propelling force (such as gravity, air, hydraulic or electric drive) then the stopping force results from inertia only – velocity at impact does not affect uniform deceleration. Under these conditions hydraulic pressure in the shock absorber will be proportional to impact velocity<sup>2</sup> which is limited to the maximum pressure rating of the shock absorber (7500 P.S.I.).
  2. Propelling Force: If any significant propelling force is present, any change in moving load weight, velocity or propelling force will require readjustment of the metering screw since stopping characteristics will be adversely affected.
  3. See "Adjustment Setting Instructions" – Efdyn Bulletin ASA-LS-No. 1 4/70.

## B. Operating Temperature \*

1. Range with Dynoil "H" Hydraulic Fluid: +20°F. to +210°F.
2. Range with Dynoil "A-1" Hydraulic Fluid: +0°F. to +190°F.
3. Range with Dynoil "B" (Silicone Fluid): -80°F. to +300°F.
4. Range with Dynoil "C" (Fire Resistant Fluid): +20°F. to +130°F.
5. Temperature Rise: Hydraulic shock absorbers convert all the kinetic energy of the moving load into heat during operation. This heat build-up causes a temperature rise within the shock absorber which is proportional to the energy absorbed, cycle rate, bore and stroke of shock absorber and ambient temperature. Radiation from the sun or other hot bodies and contact area of mounting members are contributing factors. (See Efdyn Catalog MASA-77 for heat capacity ratings.)

\*Special packings required for operation below 0°F. and above 150°F.

## C. Other Factors Influencing Successful Operation

1. Polyurethane rod packings and Viton A "O" ring seals are standard on all Efdyn Shock absorbers. Petroleum base and silicone fluids are compatible with these compounds. The shock absorber should be flushed with a suitable flushing agent when changing from one type of oil to another.
2. A polyurethane wiper-scraper is provided on the piston rod to effectively exclude contaminants from vital working parts.
3. Hydraulic fluid used must be clean, free from contaminants and capable of 100-micron (absolute) filtration.
4. Do not use fire resistant fluids unless packing compatibility has been determined. Special piston rod packing is required for phosphate ester fluids.

## VI. Maintenance

Efdyn shock absorbers will provide many years of trouble-free service provided they are properly maintained. To insure optimum performance, they should be inspected periodically for wear and proper fluid operation level. Heavy-duty applications and those which subject the shock absorbers to sand and corrosive element exposure require inspection more frequently than normally is required. Shock absorbers should be inspected for wear of piston rings, rod bearings and rod seals and for fluid contamination at least every six months. Hydraulic fluid operating levels should be checked every three months. Service replacement of worn parts is recommended as extensive wear can cause irreparable damage.

A. Oil Replacement

1. A small amount of oil wipage is normal at the piston rod gland. In fact, if a controlled amount of lubrication were not present, the seals would run dry and wear out prematurely. After long service, the piston rod seals will wear to the extent that oil replacement will become necessary more frequently. Replacement oil must be filtered to at least 100 microns (absolute) and be of the same type as is in the unit. (See Section III.)

B. Parts Replacement

1. A new set of packing and seals may be ordered and installed if oil loss becomes excessive after long service. (Order Part No. 92, Packing and Seal Kit.) These Packing and Seal Kits consist of the following:

<u>Part No.</u>	<u>Description</u>	<u>No. Req'd.</u>
10	Rod Wiper (Standard)	1
12	Piston Ring	1
15	"O" Ring (Gland Seal)	1
35	Bleeder Screw	2
56	"O" Ring (Filler Plug)	1
119	Rod Seal (Standard)	1

2. Replacement can be made as follows:
  - a. Remove bumper retaining screw and the bumper cap (taking care not to score the piston rod).
  - b. Place unit in a vertical position with piston rod upward and remove snap ring at the front head. (CAUTION – Piston rod assembly is spring loaded, for minimum spring return force in place see Paragraph I-B-1. It is recommended that the unit be placed under a press prior to removing the snap ring.)
  - c. With piston rod restrained against return spring force the gland may be removed by compressing the rod and allowing the piston rod assembly to bump out the gland on return.
  - d. Slowly relieve rod restraint and remove piston rod and gland assembly.
  - e. Remove gland and retainer assembly from piston rod.
  - f. Remove rod seal from gland, notice that rod seal lip ends face inward into gland. Remove rod wiper from retainer and gland seal from inside of front head of shock absorber body.
  - g. Install new rod seal, rod wiper and gland seal.

3. The Gland and Rod Seal Assembly (Part No. 88) should be checked at the time of disassembly. If there is evidence of excessive wear or scoring of gland bearing, the Gland Assembly (#118) should be replaced. The Gland and Rod Seal Assembly includes Gland and Rod Bearing Assembly (#118), Gland Seal (#15), Red Wiper (#10), Rod Seal (#119), and Wiper Retainer (#18).
4. Inspect the piston ring (#12) for wear or scoring. If these signs are present, replace the ring. To remove the piston ring, proceed as follows:
  - a. Replace bumper cap firmly. Be sure pins in end of piston rod are seated in matching holes in cap.
  - b. Hold rod assembly in bench vise by clamping on bumper cap to prevent rotation.
  - c. Remove piston nut (#151).
  - d. Remove piston ring retainer (#160).
  - e. Remove and replace piston ring. (Either end of ring may face pressure.)
  - f. When securing piston nut use a torque wrench and tighten as follows:

<u>Model</u>	<u>Tightening Torque</u>
MASA-1	100 in. lbs.
MASA-2	400 in. lbs.
MASA-4	800 in. lbs.

5. To replace Gland and Rod Seal Assembly (Part No. #88):
  - a. Remove bumper cap.
  - b. Hold piston and rod assembly vertically in bench vise by clamping on piston nut.
  - c. Place “torpedo” (Efdyn assembly tool Part No. 148) against end of piston rod, engaging end pins in matching holes.
  - d. Pre-assemble Gland (#118), Rod Seal (#119), Wiper Retainer (#18), Rod Wiper (#10) and Wiper Retainer Snap Ring (#16) as a group and slide over “torpedo” onto piston rod.
  - e. Replace bumper cap and lockwasher (\*#120). Torque cap screw (#21) to valve recommended below:

<u>Model</u>	<u>Tightening Torque</u>
MASA-1	100 in. lbs.
MASA-2	150 in. lbs.
MASA-4	500 in. lbs.

6. Replace "O" Ring Gland Seal (#15) in groove at front head.
7. To re-assemble shock absorber:
  - a. Place unit under arbor press.
  - b. Insert piston ring starting sleeve (Efdyn Tool #86) in open bore of front head. Since return spring will extend beyond the head, starting sleeve must be passed over spring.
  - c. Place pre-assembled piston and rod assembly on spring and press in slowly until piston has entered the cylinder bore about 3 ½ inches beyond the starting sleeve.
  - d. Hold assembly in place and remove starting sleeve.
  - e. Press gland and rod seal assembly into head bore and insert rod wiper retainer ring (#16).
  - f. Release press and replenish oil as required.
  - g. Compress and retract piston rod several times to ensure ease of piston rod return and proper assembly. The gland well around the retaining ring and piston rod should be inspected for leakage or excessive rod wipage (heavy oil film on rod) to ensure packing tightness.
  - h. Unit should be ready for operation.

C. Efdyn Reference Parts Drawings

<u>Model</u>	<u>Drawing Number</u>
MASA-1	7-0408-1-00
MASA-2	8-0121-1-00
MASA-4	7-0605-1-00

VII. Adjustment Setting Instructions

See Efdyn Technical Bulletin ASA-LS-No. 1 4/70.

PART NO.	REF. CODE	NAME
7	A1B	PISTON ROD
9	B	SPRING SEAT
10	A1B	ROD WIPER
12	A1B	PISTON RING
13	B	RETURN SPRING
16	B	RETAINING RING
18	A1B	WIPER RETAINER
19	A1B	ADJUSTING SCREW COVER
21	A1B	CAP SCREW
27	B	INTERMEDIATE SPRING GUIDE
35	A1B	BLEEDER SCREW
46	C	PRESSURE TUBE WARET FRONT BACK HEAD WELOPMENT
64	A1B	PISTON I BEARING ASSEMBLY
86	C	ROD SEAL ASSEMBLY
90	C	ADJUSTMENT SCREW ASSEMBLY
91	C	PISTON ROD ASSEMBLY
92	C	PACKING I SEAL KIT
93	C	BUNGER CAP ASSEMBLY
118	A1B	GLAND I BEARING ASSEMBLY
119	A1B	ROD SEAL
120	A1B	LOCK WASHER
157	A1B	LOCK NUT
152	A1B	DOVETAIL PIN
160	A1B	PISTON RING RETAINER

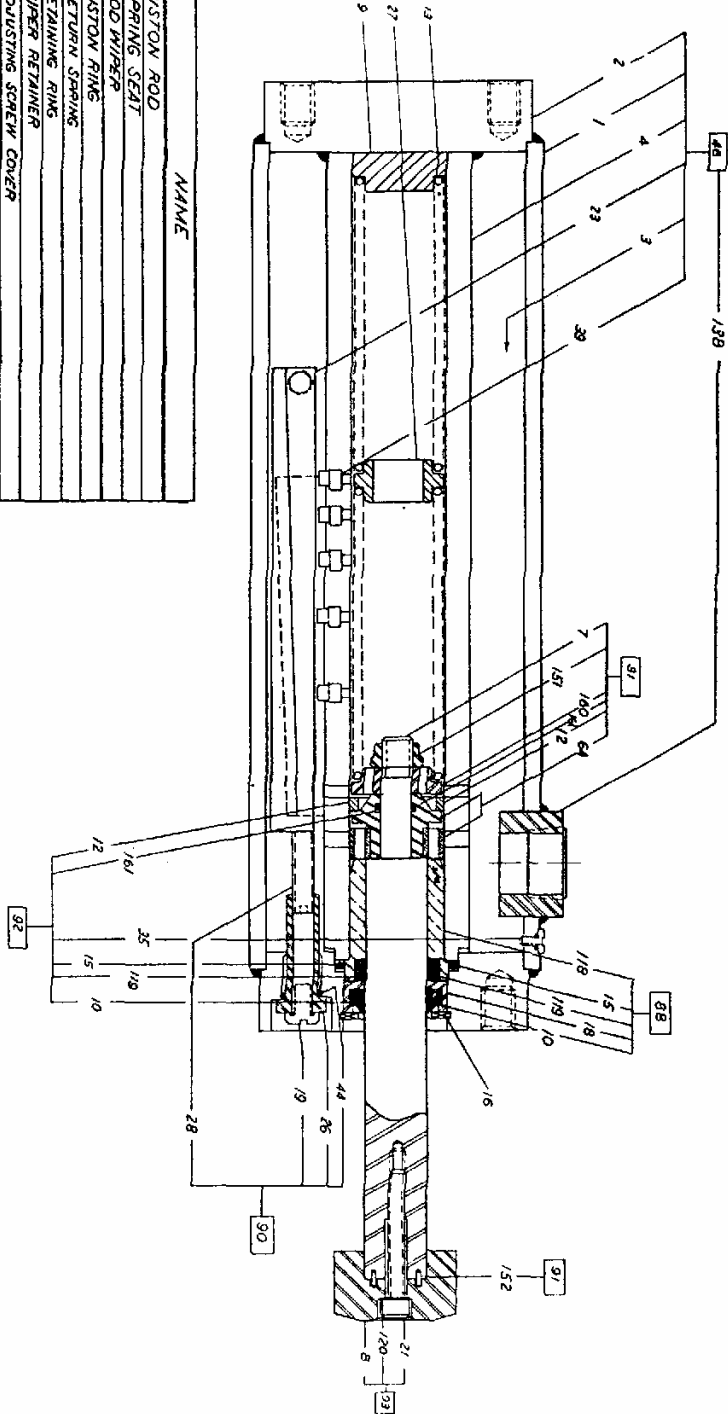

REFERENCE NOTES  
 A - SOLD IN AN ASSEMBLY  
 B - SOLD SEPARATELY  
 C - ASSEMBLY NUMBER

NOTES:  
 1 - ITEMS 7, 12, 46 & 91 SHIP WITH STROKE  
 2 - WHEN ORDERING COMPONENTS FROM THIS DRAWING ALWAYS SPECIFY THE MODEL NUMBER (MAS-11), PART NUMBER, STROKE LENGTH, SERIAL NUMBER AND DRAWING NUMBER (IF AVAILABLE).  
 3 - ITEMS 18, 118, 119 MUST BE USED TOGETHER.

20-0-8040-1  
**PARTS DRAWING**  
 MASA-1  
 DRAWN BY: TGV DATE: 7-20-77  
 CHECKED BY: JF DATE: 8-1-77  
 APPROVED BY: DATE:  
 SCALE: 3/4" = 1" IND. JOB:

THIS DRAWING IS THE PROPERTY OF  
 EFDYN CORPORATION  
 WHO CLAIMS PROPRIETARY RIGHTS IN  
 THE MATERIAL DISCLOSED. IT IS  
 ISSUED IN CONFIDENCE FOR EN-  
 GINEERING INFORMATION ONLY AND  
 MAY NOT BE COPIED OR USED FOR  
 MANUFACTURE OF ANYTHING SHOWN  
 WITHOUT SPECIFIC WRITTEN  
 PERMISSION FROM  
 EFDYN CORPORATION

REV.	DATE	CO.

TOLERANCES AND MACHINED FINISHES UNLESS OTHERWISE SPECIFIED:  
 FRACTIONS OR TWO DECIMAL PLACES  
 THREE DECIMAL PLACES  
 FOUR DECIMAL PLACES  
 ANGLES  
 FILLETS .030 RADIUS  
 BREAK SHARP CORNERS .010  
 REMOVE BURRS  
 MACHINED SURFACES 125 PPS OR BETTER

NO.	QTY	DESC.	NAME
1	1	PISTON	
2	1	PISTON RING	
3	1	PISTON PIN	
4	1	PISTON PIN BUSHING	
5	1	PISTON PIN BUSHING	
6	1	PISTON PIN BUSHING	
7	1	PISTON PIN BUSHING	
8	1	PISTON PIN BUSHING	
9	1	PISTON PIN BUSHING	
10	1	PISTON PIN BUSHING	
11	1	PISTON PIN BUSHING	
12	1	PISTON PIN BUSHING	
13	1	PISTON PIN BUSHING	
14	1	PISTON PIN BUSHING	
15	1	PISTON PIN BUSHING	
16	1	PISTON PIN BUSHING	
17	1	PISTON PIN BUSHING	
18	1	PISTON PIN BUSHING	
19	1	PISTON PIN BUSHING	
20	1	PISTON PIN BUSHING	
21	1	PISTON PIN BUSHING	
22	1	PISTON PIN BUSHING	
23	1	PISTON PIN BUSHING	
24	1	PISTON PIN BUSHING	
25	1	PISTON PIN BUSHING	
26	1	PISTON PIN BUSHING	
27	1	PISTON PIN BUSHING	
28	1	PISTON PIN BUSHING	
29	1	PISTON PIN BUSHING	
30	1	PISTON PIN BUSHING	
31	1	PISTON PIN BUSHING	
32	1	PISTON PIN BUSHING	
33	1	PISTON PIN BUSHING	
34	1	PISTON PIN BUSHING	
35	1	PISTON PIN BUSHING	
36	1	PISTON PIN BUSHING	
37	1	PISTON PIN BUSHING	
38	1	PISTON PIN BUSHING	
39	1	PISTON PIN BUSHING	
40	1	PISTON PIN BUSHING	
41	1	PISTON PIN BUSHING	
42	1	PISTON PIN BUSHING	
43	1	PISTON PIN BUSHING	
44	1	PISTON PIN BUSHING	
45	1	PISTON PIN BUSHING	
46	1	PISTON PIN BUSHING	
47	1	PISTON PIN BUSHING	
48	1	PISTON PIN BUSHING	
49	1	PISTON PIN BUSHING	
50	1	PISTON PIN BUSHING	

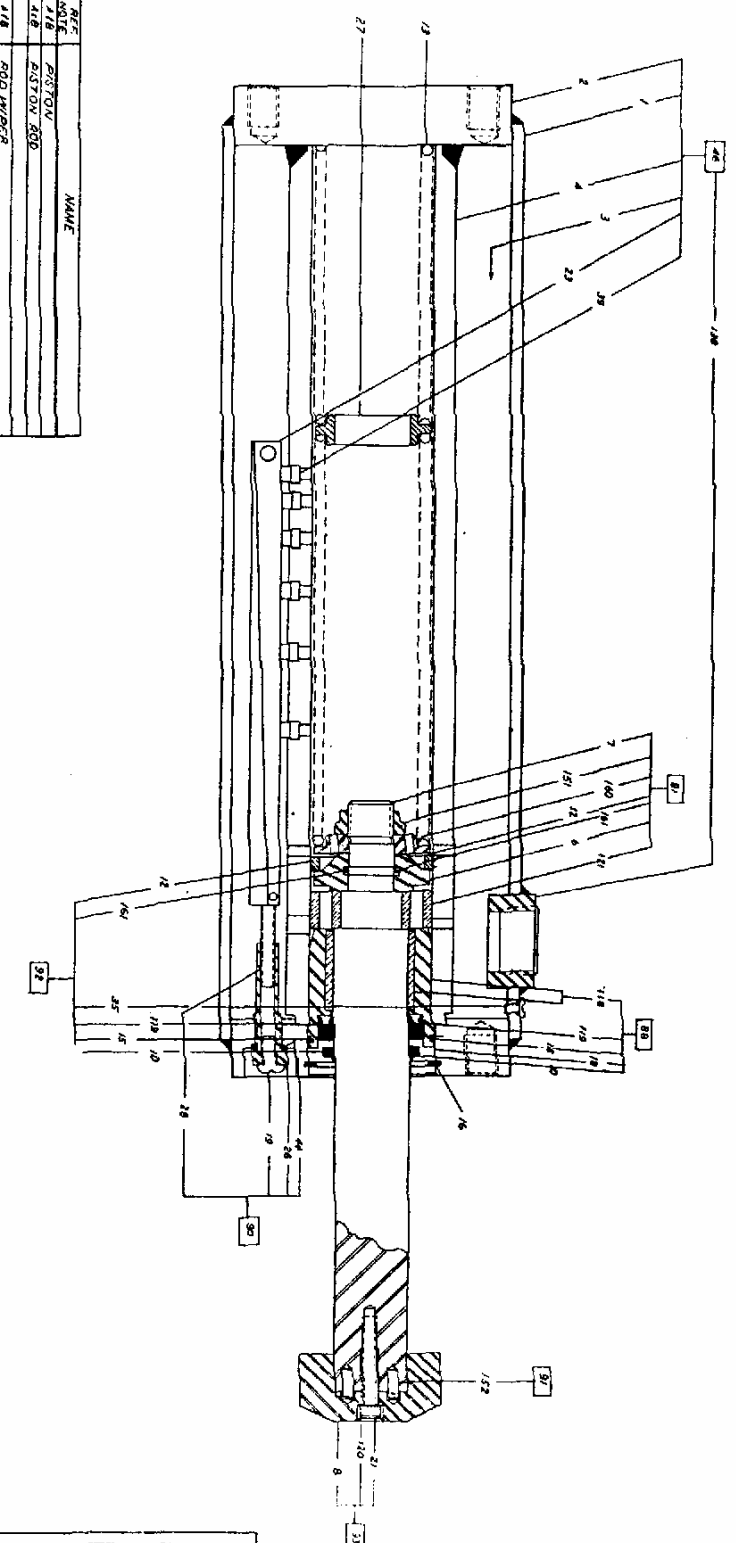

**REFERENCE NOTES:**  
 1 - ITEM 1 IN AM ASSEMBLY  
 2 - ITEM 2 IN AM ASSEMBLY  
 3 - ITEM 3 IN AM ASSEMBLY

**REMARKS:**  
 1 - ITEMS 7, 8, 9, 10, 11, 12, 13, 14, 15, 16, 17, 18, 19, 20, 21, 22, 23, 24, 25, 26, 27, 28, 29, 30, 31, 32, 33, 34, 35, 36, 37, 38, 39, 40, 41, 42, 43, 44, 45, 46, 47, 48, 49, 50, 51, 52, 53, 54, 55, 56, 57, 58, 59, 60, 61, 62, 63, 64, 65, 66, 67, 68, 69, 70, 71, 72, 73, 74, 75, 76, 77, 78, 79, 80, 81, 82, 83, 84, 85, 86, 87, 88, 89, 90, 91, 92, 93, 94, 95, 96, 97, 98, 99, 100, 101, 102, 103, 104, 105, 106, 107, 108, 109, 110, 111, 112, 113, 114, 115, 116, 117, 118, 119, 120, 121, 122, 123, 124, 125, 126, 127, 128, 129, 130, 131, 132, 133, 134, 135, 136, 137, 138, 139, 140, 141, 142, 143, 144, 145, 146, 147, 148, 149, 150, 151, 152, 153, 154, 155, 156, 157, 158, 159, 160, 161, 162, 163, 164, 165, 166, 167, 168, 169, 170, 171, 172, 173, 174, 175, 176, 177, 178, 179, 180, 181, 182, 183, 184, 185, 186, 187, 188, 189, 190, 191, 192, 193, 194, 195, 196, 197, 198, 199, 200, 201, 202, 203, 204, 205, 206, 207, 208, 209, 210, 211, 212, 213, 214, 215, 216, 217, 218, 219, 220, 221, 222, 223, 224, 225, 226, 227, 228, 229, 230, 231, 232, 233, 234, 235, 236, 237, 238, 239, 240, 241, 242, 243, 244, 245, 246, 247, 248, 249, 250, 251, 252, 253, 254, 255, 256, 257, 258, 259, 260, 261, 262, 263, 264, 265, 266, 267, 268, 269, 270, 271, 272, 273, 274, 275, 276, 277, 278, 279, 280, 281, 282, 283, 284, 285, 286, 287, 288, 289, 290, 291, 292, 293, 294, 295, 296, 297, 298, 299, 300, 301, 302, 303, 304, 305, 306, 307, 308, 309, 310, 311, 312, 313, 314, 315, 316, 317, 318, 319, 320, 321, 322, 323, 324, 325, 326, 327, 328, 329, 330, 331, 332, 333, 334, 335, 336, 337, 338, 339, 340, 341, 342, 343, 344, 345, 346, 347, 348, 349, 350, 351, 352, 353, 354, 355, 356, 357, 358, 359, 360, 361, 362, 363, 364, 365, 366, 367, 368, 369, 370, 371, 372, 373, 374, 375, 376, 377, 378, 379, 380, 381, 382, 383, 384, 385, 386, 387, 388, 389, 390, 391, 392, 393, 394, 395, 396, 397, 398, 399, 400, 401, 402, 403, 404, 405, 406, 407, 408, 409, 410, 411, 412, 413, 414, 415, 416, 417, 418, 419, 420, 421, 422, 423, 424, 425, 426, 427, 428, 429, 430, 431, 432, 433, 434, 435, 436, 437, 438, 439, 440, 441, 442, 443, 444, 445, 446, 447, 448, 449, 450, 451, 452, 453, 454, 455, 456, 457, 458, 459, 460, 461, 462, 463, 464, 465, 466, 467, 468, 469, 470, 471, 472, 473, 474, 475, 476, 477, 478, 479, 480, 481, 482, 483, 484, 485, 486, 487, 488, 489, 490, 491, 492, 493, 494, 495, 496, 497, 498, 499, 500, 501, 502, 503, 504, 505, 506, 507, 508, 509, 510, 511, 512, 513, 514, 515, 516, 517, 518, 519, 520, 521, 522, 523, 524, 525, 526, 527, 528, 529, 530, 531, 532, 533, 534, 535, 536, 537, 538, 539, 540, 541, 542, 543, 544, 545, 546, 547, 548, 549, 550, 551, 552, 553, 554, 555, 556, 557, 558, 559, 560, 561, 562, 563, 564, 565, 566, 567, 568, 569, 570, 571, 572, 573, 574, 575, 576, 577, 578, 579, 580, 581, 582, 583, 584, 585, 586, 587, 588, 589, 590, 591, 592, 593, 594, 595, 596, 597, 598, 599, 600, 601, 602, 603, 604, 605, 606, 607, 608, 609, 610, 611, 612, 613, 614, 615, 616, 617, 618, 619, 620, 621, 622, 623, 624, 625, 626, 627, 628, 629, 630, 631, 632, 633, 634, 635, 636, 637, 638, 639, 640, 641, 642, 643, 644, 645, 646, 647, 648, 649, 650, 651, 652, 653, 654, 655, 656, 657, 658, 659, 660, 661, 662, 663, 664, 665, 666, 667, 668, 669, 670, 671, 672, 673, 674, 675, 676, 677, 678, 679, 680, 681, 682, 683, 684, 685, 686, 687, 688, 689, 690, 691, 692, 693, 694, 695, 696, 697, 698, 699, 700, 701, 702, 703, 704, 705, 706, 707, 708, 709, 710, 711, 712, 713, 714, 715, 716, 717, 718, 719, 720, 721, 722, 723, 724, 725, 726, 727, 728, 729, 730, 731, 732, 733, 734, 735, 736, 737, 738, 739, 740, 741, 742, 743, 744, 745, 746, 747, 748, 749, 750, 751, 752, 753, 754, 755, 756, 757, 758, 759, 760, 761, 762, 763, 764, 765, 766, 767, 768, 769, 770, 771, 772, 773, 774, 775, 776, 777, 778, 779, 780, 781, 782, 783, 784, 785, 786, 787, 788, 789, 790, 791, 792, 793, 794, 795, 796, 797, 798, 799, 800, 801, 802, 803, 804, 805, 806, 807, 808, 809, 810, 811, 812, 813, 814, 815, 816, 817, 818, 819, 820, 821, 822, 823, 824, 825, 826, 827, 828, 829, 830, 831, 832, 833, 834, 835, 836, 837, 838, 839, 840, 841, 842, 843, 844, 845, 846, 847, 848, 849, 850, 851, 852, 853, 854, 855, 856, 857, 858, 859, 860, 861, 862, 863, 864, 865, 866, 867, 868, 869, 870, 871, 872, 873, 874, 875, 876, 877, 878, 879, 880, 881, 882, 883, 884, 885, 886, 887, 888, 889, 890, 891, 892, 893, 894, 895, 896, 897, 898, 899, 900, 901, 902, 903, 904, 905, 906, 907, 908, 909, 910, 911, 912, 913, 914, 915, 916, 917, 918, 919, 920, 921, 922, 923, 924, 925, 926, 927, 928, 929, 930, 931, 932, 933, 934, 935, 936, 937, 938, 939, 940, 941, 942, 943, 944, 945, 946, 947, 948, 949, 950, 951, 952, 953, 954, 955, 956, 957, 958, 959, 960, 961, 962, 963, 964, 965, 966, 967, 968, 969, 970, 971, 972, 973, 974, 975, 976, 977, 978, 979, 980, 981, 982, 983, 984, 985, 986, 987, 988, 989, 990, 991, 992, 993, 994, 995, 996, 997, 998, 999, 1000.

20-0-120-1-1 <b>PARTS DRAWING</b> MASA-2	THE DRAWING IS THE PROPERTY OF SP8TH CORPORATION AND IS NOT TO BE REPRODUCED OR TRANSMITTED IN ANY FORM OR BY ANY MEANS, ELECTRONIC OR MECHANICAL, INCLUDING PHOTOCOPYING, RECORDING, OR BY ANY INFORMATION STORAGE AND RETRIEVAL SYSTEM, WITHOUT THE WRITTEN PERMISSION OF SP8TH CORPORATION.	DATE: [ ] [ ] [ ] DRAWN BY: [ ] CHECKED BY: [ ] APPROVED BY: [ ]
	THIS DRAWING IS THE PROPERTY OF SP8TH CORPORATION AND IS NOT TO BE REPRODUCED OR TRANSMITTED IN ANY FORM OR BY ANY MEANS, ELECTRONIC OR MECHANICAL, INCLUDING PHOTOCOPYING, RECORDING, OR BY ANY INFORMATION STORAGE AND RETRIEVAL SYSTEM, WITHOUT THE WRITTEN PERMISSION OF SP8TH CORPORATION.	DATE: [ ] [ ] [ ] DRAWN BY: [ ] CHECKED BY: [ ] APPROVED BY: [ ]

PART NO.	QTY	NAME
6	A/B	PISTON
7	A/B	PISTON ROD
10	A/B	ROD WIPER
12	A/B	PISTON RING
13	B	RETURN SPRING
16	B	RETAINING RING
18	A/B	WIPER RETAINER
19	A/B	ADJUSTING SCREW COVER
21	A/B	CAP SCREW
27	B	INTERMEDIATE SPRING GUIDE
35	A/B	BLEEDER SCREW
46	C	PRESSURE TUBE WACKET FRONT & BACK HEAD WELDNT.
88	C	ROD SEAL ASSEMBLY
89	C	ADJUSTMENT SCREW ASSEMBLY
91	C	PISTON ROD ASSEMBLY
92	C	PACKING & SEAL KIT
93	C	BLANKET GAD ASSEMBLY
118	A/B	GLAND F BEARING ASSEMBLY
119	A/B	ROD SEAL
120	A/B	LOCK WASHER
121	A/B	PISTON BEARING
151	A/B	LOCKNUT
152	A/B	DOWEL PIN
160	A/B	PISTON RING RETAINER

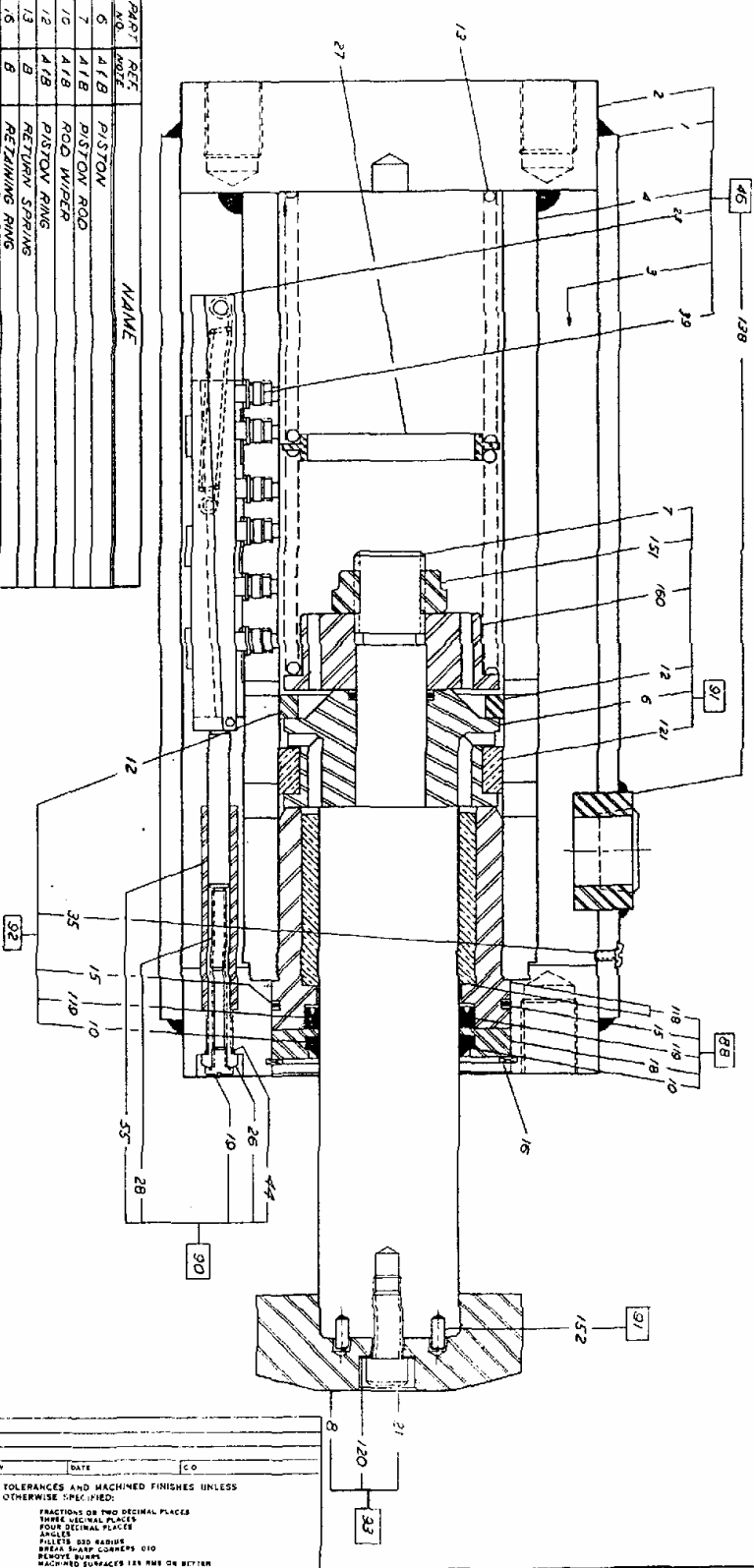

REFERENCE NOTES  
 A - SOLD IN AN ASSEMBLY  
 B - SOLD SEPARATELY  
 C - ASSEMBLY NUMBER

NOTES:  
 1- ITEMS 7, 13, 46, & 91 VARY WITH STROKE.  
 2- WHEN ORDERING COMPONENT FROM THIS DRAWING ALWAYS SPECIFY THE MODEL NUMBER (MASA-4), PART NUMBER, STROKE LENGTH, SERIAL NUMBER & DRAWING NUMBER (1-7 AVAILABLE).  
 3- ITEMS 18, 118 & 119 MUST BE TOGETHER.

**PARTS DRAWING**  
**MASA-4**

A MEMBER OF  
  
 ENGINEERING & DESIGN

DRAWN BY *TOW* DATE *7-28-77*  
 CHECKED BY *LT* DATE *8-1-77*  
 APPROVED BY \_\_\_\_\_ DATE \_\_\_\_\_  
 SCALE: *1/2" = 1"* JOB: \_\_\_\_\_

THIS DRAWING IS THE PROPERTY OF EFDVN CORPORATION WHO CLAIMS PROPRIETARY RIGHTS IN THE MATERIAL DISCLOSED. IT IS ISSUED IN CONFIDENCE FOR ENGINEERING INFORMATION ONLY AND MAY NOT BE COPIED OR USED FOR REPRODUCTION OF ANYTHING OTHER THAN THE ORIGINAL WITHOUT SPECIFIC WRITTEN PERMISSION FROM EFDVN CORPORATION.

DATE: \_\_\_\_\_  
 TOLERANCES AND MACHINED FINISHES UNLESS OTHERWISE SPECIFIED:  
 FRACTIONS OR TWO DECIMAL PLACES  
 THREE DECIMAL PLACES  
 FOUR DECIMAL PLACES  
 PILETS .030 RADIUS  
 BREAK SHARP CORNERS 0.10  
 REMOVE BURRS  
 MACHINED SURFACES PER THE OR BETTER

7-0605-0-02