



Simple solutions to your urgent problems.

## KINETROL LTD. Model LE Dashpot

### SPECIFICATION

<b>Rate</b>	Adjustable Max (LE4): 3,000 Nm/rad/s 26,550 lbf.ins/rad/s)
<b>Angle of travel</b>	220° ± 5° External end stops must be provided
<b>Max. safe torque</b>	4,820 lbf.ins/ 545 Nm Continuous power dissipation not To exceed 200W at 68°F ambient
<b>Max. shaft end load</b>	224 lbf / 1,000 N pulling on shaft 18 lbf / 80 N pushing on shaft
<b>Max. shaft side load</b>	340 lbf / 1,500 N
<b>Ambient temperature range</b>	32° to 140°F
<b>Frictional torque</b>	27 lbf.ins / 3 Nm typical
<b>Shaft material</b>	Stainless steel 431S29
<b>Body material</b>	Aluminum alloy LM25
<b>Weight</b>	26 lbs/ 12 kg

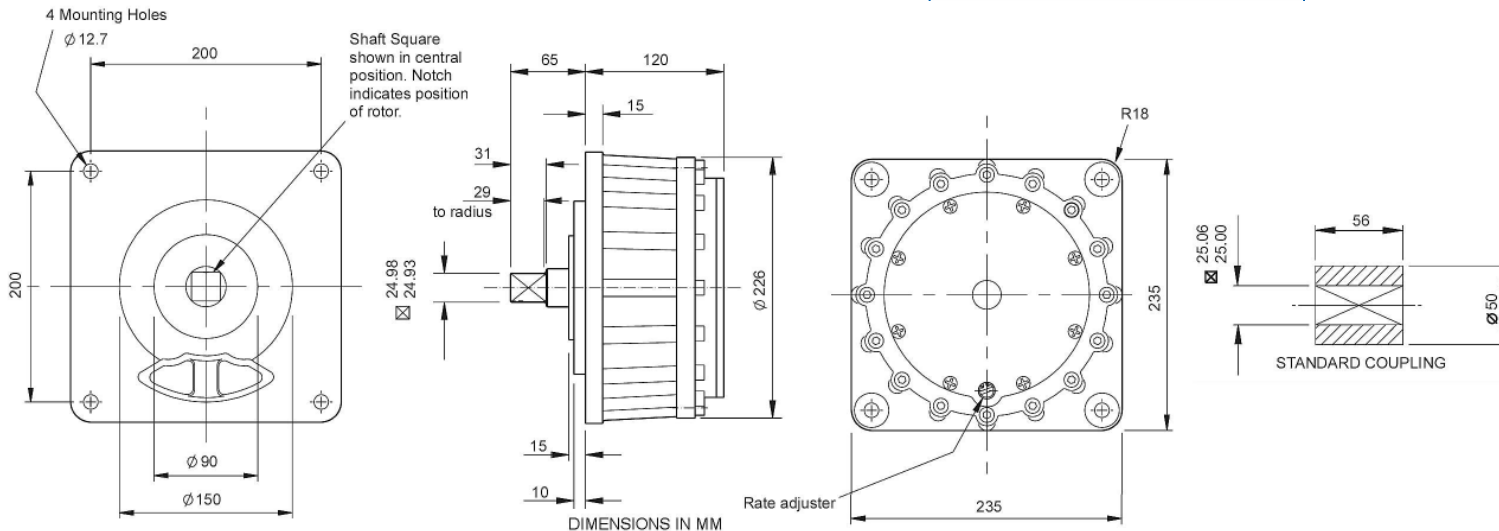

### RATES

An adjuster permits any damping rate to be obtained within one of the following ranges. This range must be specified when ordering the dashpot.

- **LE1:** 443 to 3,100 lbf.ins/rad/s / 50 to 350 Nm/rad/s
- **LE2:** 885 to 6,200 lbf.ins/rad/s / 100 to 700 Nm/rad/s
- **LE3:** 1770 to 13,275 lbf.ins/rad/s / 200 to 1,500 Nm/rad/s
- **LE4:** 3,540 to 26,550 lbf.ins/rad/s / 400 to 3,000 Nm/rad/s

With adjuster set to maximum the rate may exceed stated maximum and with adjuster set to minimum the rate may be less than stated minimum.

### OPTIONS

The following features may be specified for any model:

**Differential Rate (FC or FAC)**

Gives resistance in one direction only and less than 1/10 resistance in the other. Specify free clockwise or free counterclockwise when viewed from shaft end.

**Double Damping (DD)**

Gives equal resistance in either direction.

**Couplings**

Steel couplings available.

### ORDERING CODES

- LE1, 2, 3 or 4 – DD
- LE1, 2, 3 or 4 – FC or FAC

Kinetrol LTD. Rotary dashpots distributed through:

Efdyn, Incorporated  
7734 East 11<sup>th</sup> Street  
Tulsa, Oklahoma 74112

[www.efdyn.com](http://www.efdyn.com)

Toll Free: 800-950-1172  
Phone: 918-838-1170  
sales@efdyn.com



Simple solutions to your urgent problems.

# KINETROL LTD. Model LE Dashpot

## TEMPERATURE EFFECTS

Damping rate is reduced by increases in fluid temperature (and increased by reduction in temperature). The graph below indicates the percentage change in damping rate with temperature, relative to the rate quoted at 20°C.

Dashpots compensated for temperature change, to keep damping rate constant, can be special ordered.

In addition to the effect of ambient temperature, heating of the dashpot above ambient is caused by the power absorbed by the damping action. Power dissipation limits are given for 20°C ambient. At temperatures above 20°C these power limits are de-rated by a factor:

$$(T_L - T_A) / (T_L - 20)$$

where  $T_L$  = Limit Temperature and  $T_A$  = Ambient Temperature

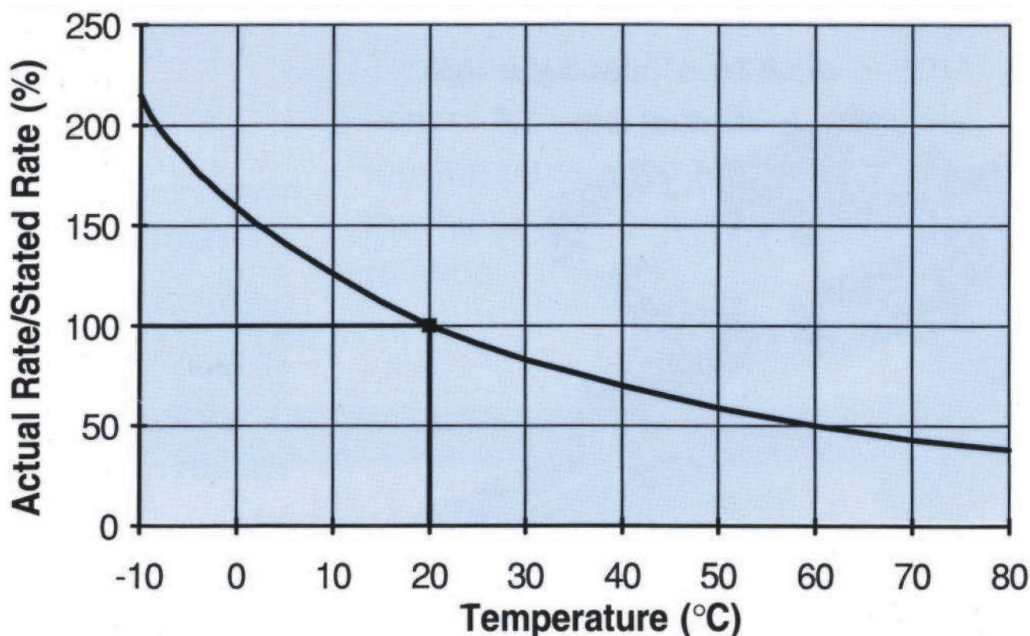

## CONVERSION FACTORS

1 rad = 57.3°  
1 Nm = 8.85 lbf.ins

1 RPM = 0.1047 rad/s  
1 lbf = 4.45 N

1 lbf.ins = 0.113 Nm  
9.81N = 1 kgf = 1 kp

## GENERAL NOTES

- For calculation purposes the rotation speed of the dashpot is given in RADIANS per second (1 radian = 57.3°). The significance of a radian is that if, for example, a 1 meter radius lever rotates through 1 radian, the end of the lever moves 1 meter, a distance equal to the radius.
- Damping RATE is defined here as TORQUE divided by ROTATION SPEED. Note that a dashpot with a high rate may not necessarily be working at a high torque. For example, a dashpot may have a rate of 100 Nm/rad/s; however, it may be rotated at 1/10 rad/s so that the damping torque produced is 10 Nm which is not numerically equal to the rate.

Kinetrol LTD. Rotary dashpots distributed through:

Efdyn, Incorporated  
7734 East 11<sup>th</sup> Street  
Tulsa, Oklahoma 74112

[www.efdyn.com](http://www.efdyn.com)

Toll Free: 800-950-1172  
Phone: 918-838-1170  
sales@efdyn.com