

SAS 1/2", 3/4" & 1 1/8" BORE MODEL

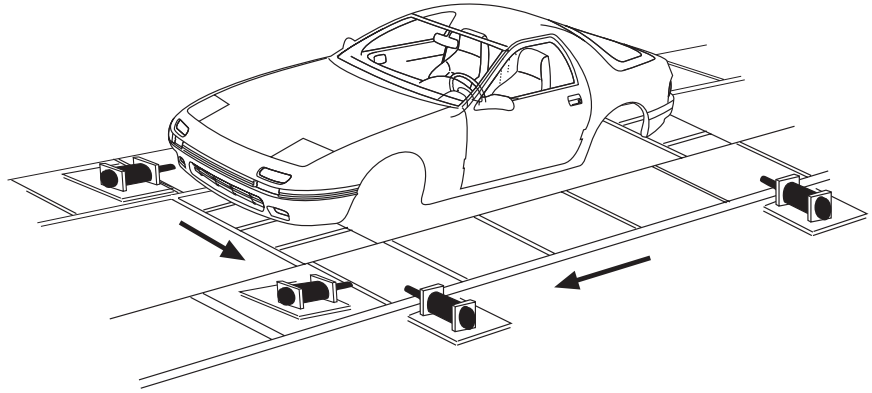

SAS 1/2", 3/4" & 1 1/8"

MODEL	WE EFFECTIVE WEIGHT (lbs.)			ENERGY PER CYCLE (In-lbs)	ENERGY PER HOUR (In-lbs)		(B) WE x V ²	WEIGHT lbs
	LM (LIGHT)	MH (MEDIUM)	HV (HEAVY)		SELF CONTAINED	AIR RETURN		
SAS 1/2 x 1	10 - 360	30 - 1,080	90 - 3,240	440	750,000	1,700,000	2,850	.75
SAS 1/2 X 2	15 - 540	45 - 1,620	135 - 4,860	880	870,000	1,800,000	5,700	1
SAS 1/2 X 2 1/2	18 - 640	55 - 1,980	165 - 5,940	1,100	930,000	1,850,000	7,125	1.5
SAS 1/2 X 3	20 - 720	60 - 2,160	180 - 6,480	1,320	990,000	1,900,000	8,550	1.75
SAS 3/4 X 1	30 - 1,080	100 - 3,600	500 - 18,000	1,450	1,100,000	3,100,000	9,340	3
SAS 3/4 X 2	40 - 1,440	125 - 4,500	600 - 21,600	2,900	1,300,000	3,300,000	18,680	4
SAS 3/4 X 3	50 - 1,800	150 - 5,400	700 - 25,200	4,350	1,600,000	3,600,000	28,020	5
SAS 3/4 X 4	60 - 2,160	200 - 7,200	1,000 - 36,000	5,800	1,800,000	3,800,000	37,360	6
SAS 1 1/8 X 2	75 - 2,700	200 - 7,200	1,000 - 36,000	7,900	1,500,000	4,500,000	42,403	8
SAS 1 1/8 X 4	100 - 3,600	300 - 10,800	2,000 - 72,000	15,800	2,000,000	5,000,000	84,807	11
SAS 1 1/8 X 6	150 - 4,500	400 - 14,400	3,000 - 108,000	23,800	2,500,000	5,500,000	127,211	15

HOW TO ORDER SAS SHOCK ABSORBERS

The model designation for SAS self-adjusting shock absorbers is a coded description of the unit defined as shown in this example.

SAS•3/4•2•FS•MH•99

Efdyn's Self Adjusting Shock Absorber	Nominal Bore Size 3/4 or 1 1/8	Stroke Length	Piston Rod Return Method S-Spring Return A-Air (External Accumulator Required)	Selected Metering Designation	Designates Standard Unit Without Modifications
Mounting Style • P-Primary • B-Sq. Back Flange • F-Sq. Front Flange • BT-Rectangular Back Flange • R-Rod Eye • C-Rod Clevis • H-Hinge Mount • L-Lug Mount (Front & Rear) • FT-Rectangular Front Flange					

INFORMATION NEEDED FOR SIZING SHOCKS

W - Weight of moving objects (lbs.)

V - Impact Velocity (FPS)

F_P - Driving (propelling) Force (lbs.)

S - Stroke (inches)

- If no propelling force (F) exists then $W_e = W$.
- The maximum velocity allowable for a shock absorber can be determined by using (B) values in the table.
- Minimum velocity is 1.0 FPS for all load ranges.

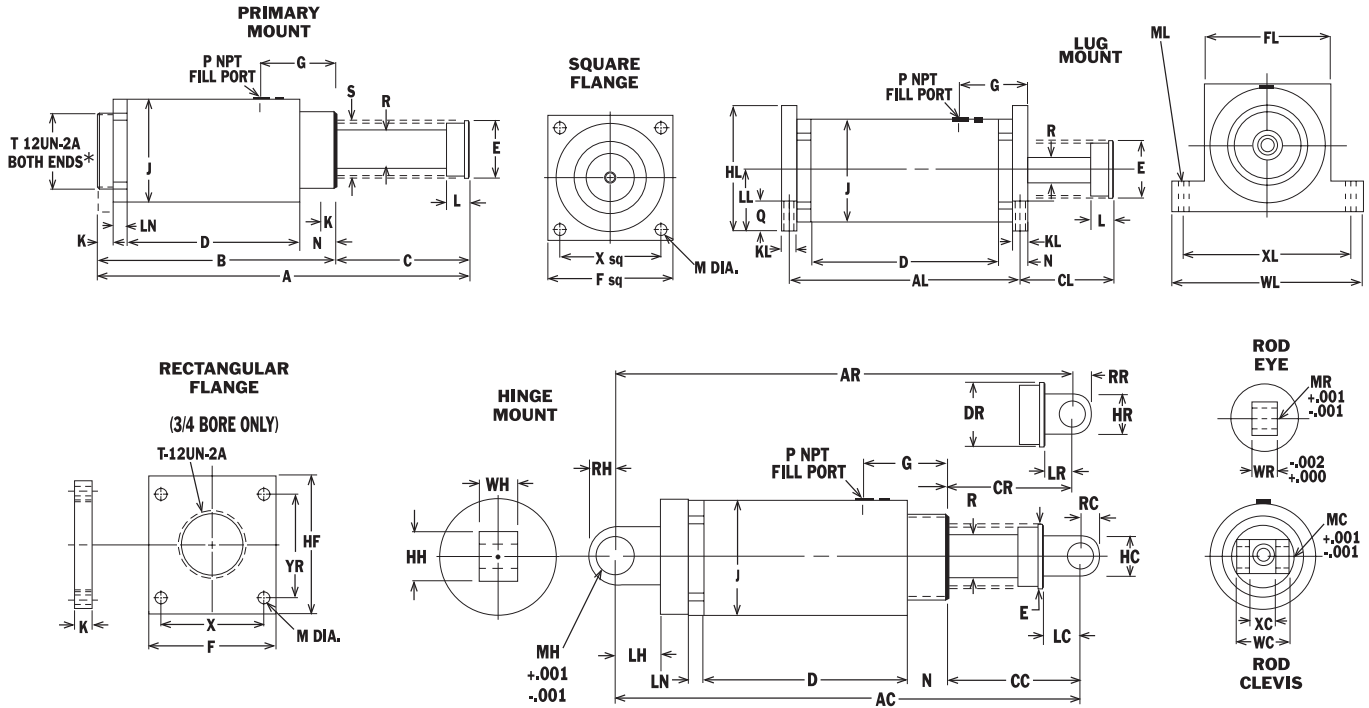

*Metric thread is m64 x 2.0 (available on the 1 1/8" bore model only)

DIMENSIONS IN INCHES													
MODEL	STROKE	A	AC	AR	AL	B	C	CC	CL	CR	D	E	S
SAS 1/2 X 1	1	5.45	N/A	N/A	N/A	3.25	2.20	N/A	N/A	N/A	1.98	1.00	.98
SAS 1/2 X 2	2	7.45	N/A	N/A	N/A	4.25	3.20	N/A	N/A	N/A	2.48	1.00	.98
SAS 1/2 X 2 1/2	2 1/2	8.88	N/A	N/A	N/A	4.75	4.13	N/A	N/A	N/A	2.98	1.00	.98
SAS 1/2 X 3	3	9.88	N/A	N/A	N/A	5.25	4.63	N/A	N/A	N/A	3.98	1.00	.98
SAS 3/4 X 1	1	5.69	7.84	N/A	3.34	3.72	1.97	2.56	2.15	N/A	1.97	1.50	1.31
SAS 3/4 X 2	2	7.69	9.84	N/A	4.34	4.72	2.97	3.56	3.15	N/A	2.97	1.50	1.31
SAS 3/4 X 3	3	9.69	11.84	N/A	5.34	5.72	3.97	4.56	4.15	N/A	3.97	1.50	1.31
SAS 3/4 X 4	4	13.06	15.21	N/A	6.34	6.72	6.34	6.93	6.15	N/A	4.97	1.50	1.31
SAS 1 1/8 X 2	2	8.88	12.16	11.63	4.88	5.50	3.38	4.79	3.69	4.26	3.44	2.00	1.88
SAS 1 1/8 X 4	4	12.88	16.16	15.63	6.88	7.50	5.38	6.79	5.69	6.26	5.44	2.00	1.91
SAS 1 1/8 X 6	6	17.75	20.84	20.31	8.88	9.50	8.25	9.47	8.56	8.94	7.44	2.75*	2.73

* For air use 2.00

COMMON DIMENSIONS IN INCHES																				
MODEL	DR	F	FL	G	HC	HF	HH	HL	HR	J	K	KL	L	LC	LH	LL	LN	LR	M	MC
SAS 1/2	N/A	2.00	2.00	.91	N/A	N/A	N/A	2.00	N/A	1.50	.38	.38	.50	N/A	N/A	1.00	.25	N/A	.22	N/A
SAS 3/4	N/A	2.25	2.25	1.23	1.00	3.00	1.00	2.25	N/A	2.25	.50	.63	.63	.69	1.06	1.15	.38	N/A	.34	.3765
SAS 1 1/8	2.00*	3.50	3.50	1.63	1.38	N/A	1.94	3.50	1.13	3.00	.63	.63	1.00	1.41	1.31	1.75	.38	1.13	.41	.7515
	MH	ML	MR	N	P	Q	R	RC	RH	RR	T	WC	WH	WL	WR	X	XC	XL	YR	
SAS 1/2	N/A	.22	N/A	.61	.125	.38	.38	N/A	N/A	N/A	1.25	N/A	N/A	3.00	N/A	1.50	N/A	2.50	N/A	
SAS 3/4	.5015	.34	N/A	.88	.125	.56	.50	.50	.50	N/A	1.75	1.00	.75	3.75	N/A	1.63	.52	3.00	2.38	
SAS 1 1/8	.7515	.42	.501	1.03	.250	.75	.75	.69	.75	.63	2.50	1.50	1.25	5.63	.75	2.75	.63	4.88	N/A	

* Use 2.75 on 6" stroke spring return

SAS 1/2", 3/4" & 1 1/8"