

SAS 1½" & 2" BORE MODEL

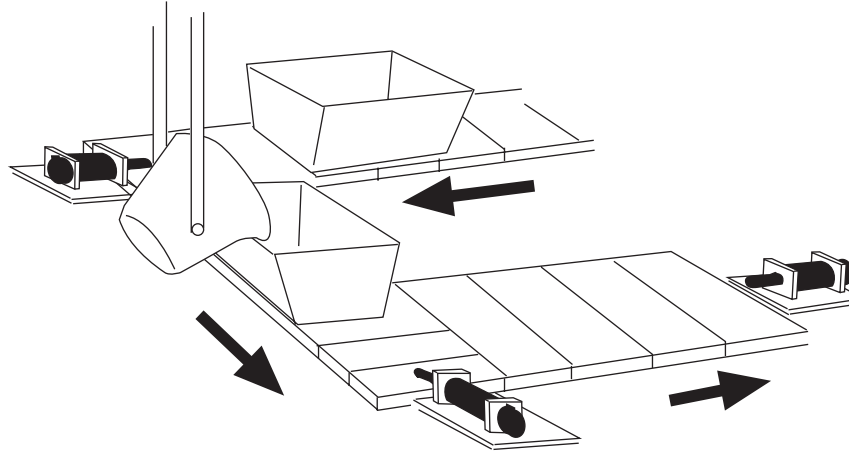

SAS 1½" & 2"

BORE	STROKE	WE EFFECTIVE WEIGHT (lbs.)			ENERGY PER CYCLE (In-lbs)	ENERGY PER HOUR (In-lbs)		(B) WE x V ²	WEIGHT lbs
		LM (LIGHT)	MH (MEDIUM)	HV (HEAVY)		SELF CONTAINED	AIR RETURN		
1½	2	200 – 7,200	1,000 – 36,000	2,000 – 72,000	14,100	1,800,000	4,800,000	75,384	15
	3 1/2	250 – 9,000	1,500 – 54,000	3,000 – 108,000	24,600	2,100,000	5,100,000	131,923	17
	5	300 – 10,800	2,000 – 72,000	4,000 – 144,000	35,200	2,500,000	5,500,000	188,461	21
	6 1/2	350 – 12,600	2,500 – 90,000	5,000 – 180,000	45,800	2,900,000	5,900,000	244,998	24
	8	400 – 14,400	3,000 – 108,000	6,000 – 216,000	56,300	3,200,000	8,200,000	301,538	28
	10	450 – 16,200	3,500 – 126,000	7,000 – 252,000	70,400	3,800,000	8,800,000	376,922	32
2	2	500 – 18,000	2,000 – 72,000	3,000 – 108,000	24,600	3,600,000	8,600,000	131,923	35
	4	750 – 27,000	2,500 – 90,000	5,000 – 180,000	49,300	4,300,000	9,300,000	263,846	41
	6	1,000 – 36,000	3,000 – 108,000	7,000 – 252,000	74,000	5,000,000	13,000,000	395,769	48
	8	1,250 – 45,000	3,500 – 126,000	9,000 – 324,000	99,000	5,700,000	14,000,000	527,692	55
	10	1,500 – 54,000	4,000 – 144,000	11,000 – 396,000	123,000	6,400,000	17,000,000	659,615	61

HOW TO ORDER SAS SHOCK ABSORBERS

The model designation for SAS self-adjusting shock absorbers is a coded description of the unit defined as shown in this example.

SAS • 1½ • 2 • FS • MH • 99

Efdyn's Self Adjusting Shock Absorber	Nominal Bore Size 1 1/2 or 2	Stroke Length	Piston Rod Return Method S - Spring Return A - Air (External Accumulator Required)	Selected Metering Designation	Designates Standard Unit Without Modifications
---------------------------------------	------------------------------	---------------	--	-------------------------------	--

Mounting Style • P-Primary • B-Sq. Back Flange • F-Sq. Front Flange • BT-Rectangular Back Flange • R-Rod Eye • C-Rod Clevis • H-Hinge Mount • L-Lug Mount (Front & Rear) • FT-Rectangular Front Flange

INFORMATION NEEDED FOR SIZING SHOCKS

W - Weight of moving objects (lbs.)

V - Impact Velocity (FPS)

F_p - Driving (propelling) Force (lbs.)

S - Stroke (inches)

- If no propelling force (F) exists then $W_e = W$.
- The maximum velocity allowable for a shock absorber can be determined by using (B) values in the table.
- Minimum velocity is 1.0 FPS for all load ranges.

— ASK ABOUT OUR EXPEDITE SERVICE! —

www.efdyn.com

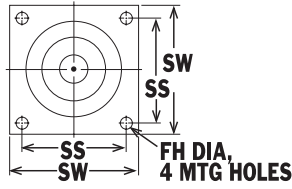

SQUARE FLANGE

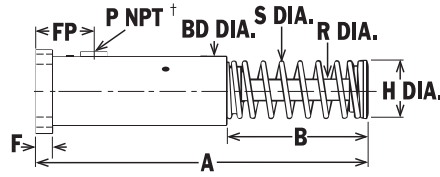

BACK FLANGE MOUNT

† Single port- standard
Double Port- optional

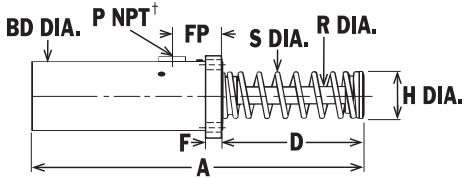

RECTANGULAR FLANGE

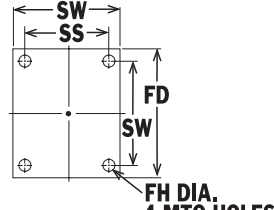

RECTANGULAR FLANGE

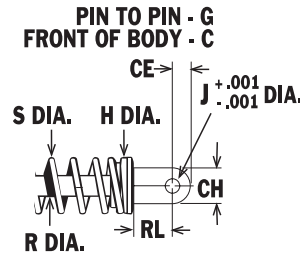

**PIN TO PIN - G
FRONT OF BODY - C**

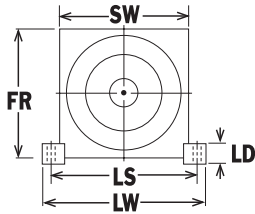

LUG MOUNT

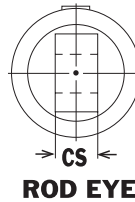
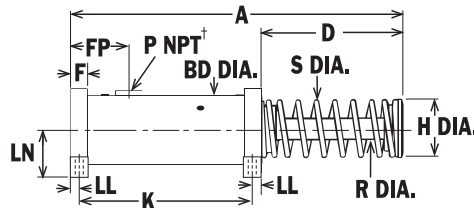

ROD EYE

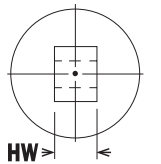

HINGE MOUNT

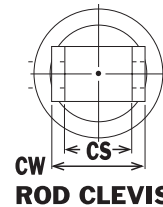
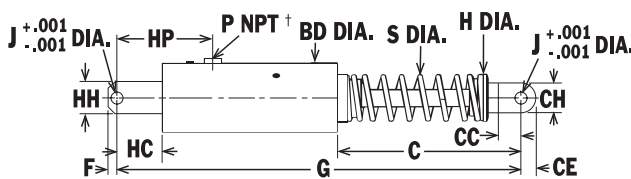

ROD CLEVIS

DIMENSIONS IN INCHES

STROKE	A		B		C		D		G		H	K	S	HC	HP
	STD	FDY	STD	FDY	STD	FDY	STD	FDY	STD	FDY					
1 1/2 X 2 S & A	9.71	10.46	4.33	5.08	6.08	6.58	4.15	4.90	12.93	13.68	2.75	5.18	2.75	1.50	3.50
1 1/2 X 3 1/2 S & A	12.71	13.46	5.83	6.58	7.58	8.33	5.65	6.40	15.96	16.71	2.75	6.88	2.75	1.50	3.50
1 1/2 X 5 S & A	15.71	16.46	7.33	8.08	9.08	9.83	7.15	7.90	18.96	19.71	2.75	8.18	2.75	1.50	3.50
1 1/2 X 6 1/2A	19.46	19.46	9.58	9.58	11.33	11.33	9.40	9.40	22.71	22.71	2.75	9.68	N/A	1.50	3.50
1 1/2 X 6 1/2S	19.46	19.46	9.58	9.58	11.33	11.33	9.40	9.40	22.71	22.71	3.00	9.68	2.75	1.50	3.50
1 1/2 X 8A	22.46	22.46	11.08	11.08	12.83	12.83	10.90	10.90	25.71	25.71	2.75	11.18	N/A	1.50	3.50
1 1/2 X 8S	22.96	22.96	11.58	11.58	13.33	13.33	11.40	11.40	26.21	26.21	3.50	11.18	3.00	1.50	3.50
1 1/2 X 10A	26.46	26.46	13.08	13.08	14.83	14.83	12.90	12.90	29.71	29.71	2.75	13.18	N/A	1.50	3.50
1 1/2 X 10S	26.96	26.96	13.58	13.58	15.33	15.33	13.40	13.40	30.21	30.21	4.00	13.18	3.50	1.50	3.50
2 X 2 S & A	12.31	12.81	4.56	5.06	6.59	6.59	4.31	4.81	17.00	17.00	3.12	9.50	3.12	2.66	6.16
2 X 4 S & A	16.31	16.81	6.56	7.06	8.59	8.59	6.31	6.81	21.00	21.00	3.12	11.50	3.12	2.66	6.16
2 X 6 S & A	20.31	20.81	8.56	9.06	10.59	10.59	8.31	8.81	25.00	25.00	3.12	13.50	3.12	2.66	6.16
2 X 8A	24.31	24.81	10.56	11.06	13.59	13.59	10.31	10.81	29.00	29.00	3.12	15.50	N/A	1.66	5.16
2 X 8S	25.31	25.31	11.56	11.56	13.33	13.33	11.31	11.31	29.00	29.00	4.12	15.50	4.12	1.66	5.16
2 X 10A	28.31	28.81	13.06	13.06	15.59	15.59	12.31	12.81	33.00	33.00	3.12	17.50	N/A	1.66	5.16
2 X 10S	29.31	29.31	13.56	13.56	15.59	15.59	13.31	13.31	33.00	33.00	4.50	17.50	4.50	1.66	5.16

DIMENSIONS IN INCHES

BORE	BD	CC	CE	CH	CS	CW	F	FD	FH	FP	FR	HH	HW	J	LD	LL	LN	LS	LW	P	R	RL	SS	SW
1 1/2	3.50	1.41	.62	1.25	.62	1.50	.75	5.00	.531	2.00	4.03	1.50	1.25	.750	.75	.48	2.03	5.50	6.50	.50	1.125	2.00	3.00	4.00
2	5.00	1.31	1.00	2.00	1.50	3.00	1.00	N/A	.656	3.50	5.87	2.25	1.50	1.000	1.50	.62	3.12	6.50	8.00	.75	1.500	2.25	4.38	5.50