

MASA EXTRA HEAVY DUTY ADJUSTABLE

1 1/8", 2", & 4" BORE



- HIGH CAPACITY IN CONJUNCTION WITH A COMPACTNESS DESIGNED TO FIT TIGHT PLACES
- AVAILABLE IN 2, 4, 6, 8 AND 10 INCH STROKE LENGTHS IN BOTH SPRING AND AIR RETURN MODELS
- UNIFORM DECELERATION WHERE LOAD CONDITIONS VARY WIDELY

Dimensions Common To Spring Or Air Return			
Symbol	Bore Size (Inches)		
	1 1/8	2	4
B	1 1/8	2	4
C	3/4	1 1/4	2 1/2
D	7/8	1 3/16	1 3/4
E	1 1/2	2 3/8	4 3/4
F	3/4	1	1 1/2
G	2 1/2	3 1/2	6 7/8
H	3 1/2	5	8 1/4
J	3/4	1	2 1/8
K	1 1/4	1 13/16	2 13/16
L	4	5 1/2	10
M	3 1/4	4 1/2	8 3/8
N	2 3/4	4	6 3/8
P	13/32	17/32	1 1/16
Q	3/8 -24	1/2-20	1-14
R	9/16	11/16	1 5/16
S*	3/4 -16	1 5/16 - 12	1 5/8 - 12
T	1 3/4	2	4
U	1 1/8	1 11/16	3 1/16
V	17/32	17/32	13/16
W	7/16	9/16	7/8
X	1 1/2	2 7/16	3 3/4
Y	5/8	1	1 1/2
Z	7/8	1 1/2	2 1/4
BB	3 1/2	4 5/8	8 3/4
CB	1 1/4	1 1/2	2 1/2
CC	2 5/8	3 1/2	7
CD	3/4	1	1 3/4
CF	1	1 5/16	2 1/4
CL	2	2 3/4	4 1/2
CR	3/4	1	1 3/4
CW	5/8	3/4	1 1/4
DC	1/2	1	1 3/4
DD	1 15/16	2 5/8	4 3/8
EE	1 1/8	1 3/8	2 1/2
FC	1	2	3 1/2
FF	7/8	1 1/2	2 1/4
GG	4 1/2	6 1/4	10 1/8
HH	3 5/8	5 1/8	8 3/8
JJ	1 7/16	1 13/16	3 11/16
KK	5/8	1	1 1/2
LC	1 7/8	3 3/8	4 3/4
LL	15/32	21/32	1 1/16
MM	3/4	1	1 1/2
RC	1/2	1	1 3/4
SC	3/8	9/16	3/4
WC	3/4	1 1/2	2 1/2

Note: NPT ports are standard
 *S= SAE Straight thread ports (optional)

Stroke**	***MAXIMUM WORKING CAPACITY Inch-Lbs.			*HEAT DISSIPATION CAPACITY Inch-Lbs. Per Hour					
	Bore Size			Bore Size (Spring Return Models)			Bore Size (Air Return Models)		
	1 1/8	2	4	1 1/8	2	4	1 1/8	2	4
2	15,000	47,000	-	2,700,000	4,480,000	-	8,190,000	13,900,000	-
4	30,000	94,000	376,000	3,850,000	6,007,000	13,180,000	10,810,000	17,100,000	31,060,000
6	45,000	141,000	564,000	-	7,410,000	15,030,000	10,810,000	17,100,000	34,800,000
8	-	188,000	752,000	-	-	16,700,000	-	19,235,000	38,590,000
10	-	-	940,000	-	-	-	-	-	38,590,000

* Heat capacity ratings are based on still air conditions (80°F ambient) and max. hydraulic fluid operating temperature of 200°F. Spring return model ratings apply to self-contained units. Air return model ratings apply to units with circulating hydraulic systems (external reservoir - double connecting ports). Heat capacity ratings can be increased using special fluid and seals and/or heat exchanger systems. Consult factory.

** When load propelling force exceeds 25% of total stopping force, based on maximum unit capacity rating, external mechanical load stops are recommended. Mechanical load stops must be positioned to allow piston rod to compress to within 1/16" of completing full stroke. If mechanical load stops cannot be positioned this accurately, specify piston rod extension for additional clearance as full stroke must be utilized for proper unit performance.

*** Consult factory for optimum adjustability if unit selected will be used above 80% of its max. working capacity rating when impact velocities are 1.0 FPS or less, and under 60% of its max. working capacity rating when impact velocities are 15.0 FPS or greater. For front flange mounts, use 65% of above working capacity ratings.

Stroke	Air Return Bore Size (Inches)			Stroke	Dimension A Spring Return Bore Size (Inches)		
	1 1/8	2	4		1 1/8	2	4
2	7 7/8	8 5/8	-	2	7 7/8	8 5/8	-
4	11 3/4	12 5/8	15	4	11 3/4	12 5/8	15
6	11 3/4	12 5/8	17 7/8	6	-	16 5/8	17 7/8
8	-	16 5/8	21 1/4	8	-	-	21 1/4
10	-	-	21 1/4	10	-	-	-

MASA 1 1/8", 2" & 4"

HYDRAULIC SHOCK ABSORBER



- 8 Bumper Cap
- 9 Spring Seat (MASA-1 only)
- 10 Rod Wiper
- 12 Piston Ring
- 13 Return Spring
- 15 O-Ring
- 16 Retaining Ring
- 17 Rod Seal
- 18 Wiper Retainer
- 19 Adjusting Screw
- 21 Cap Screw
- 26 Adjusting Screw Bushing
- 27 Spring Spacer
- 28 Adjustment Screw
- 173 Filler Plug
- 35 Bleed Screw
- 44 O-Ring
- 91 Piston Rod and Piston
- 55 Wedge Rod (MASA-4 only)
- 118 Gland Bearing
- 120 Lock Washer
- 121 Piston Bearing

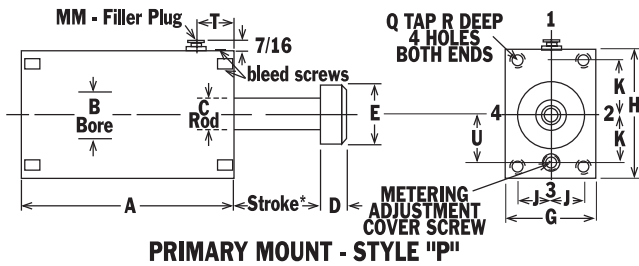
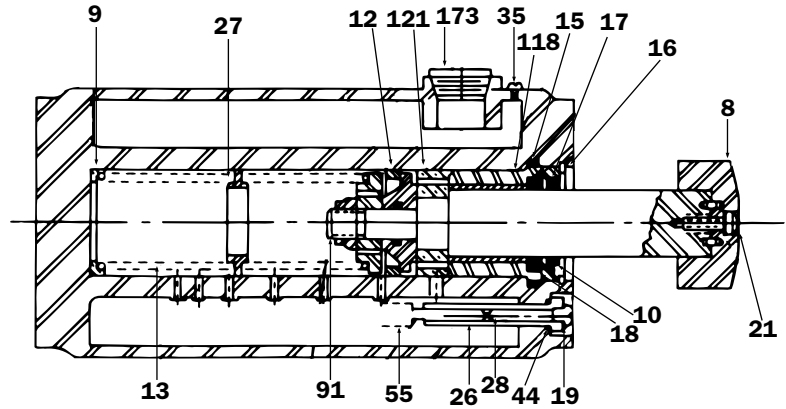

HOW TO ORDER MASA SHOCK ABSORBERS

MASA • 1 • 2 • BS • 99

Efdyn's Adjustable Shock Absorber Prefix	Nominal Bore Size	Stroke Length	Piston Rod Return Method S-Spring Return A-Air (External Accumulator Required)	Designates Standard Unit Without Modifications
Mounting Style • P-Primary • B- Back Flange • F- Front Flange • L-Lug • S- Side Mount • HC- Hinge-Clevis • HR- Hinge-Rod eye				

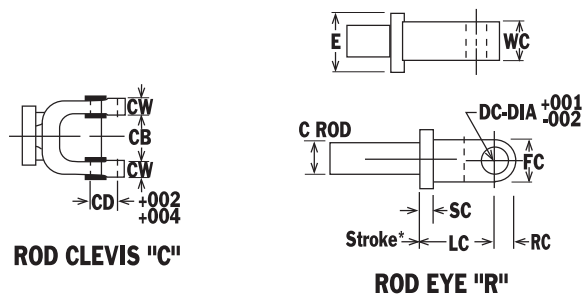
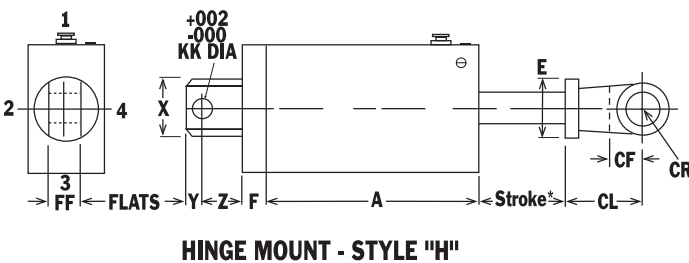
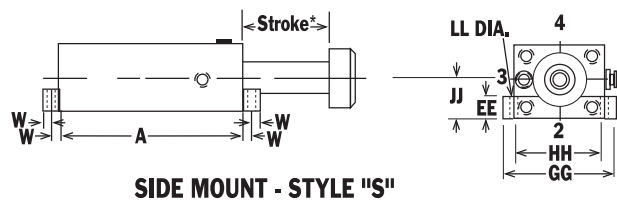
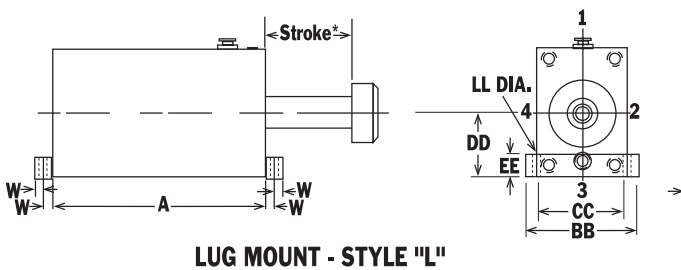
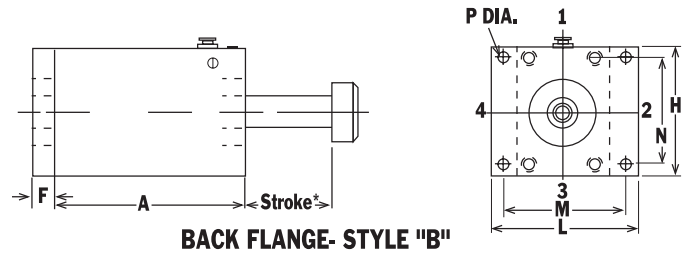
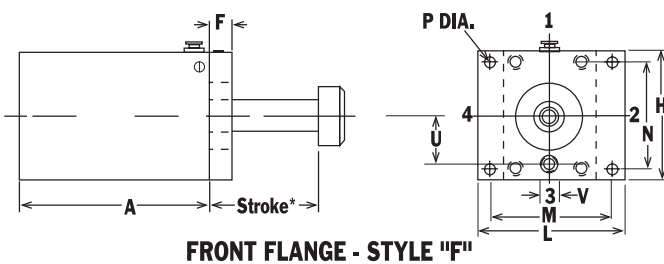

* For foundry service, add 1/2" rod extension on back flange hinge and lug mount units and 2" rod extension for front flange mount units.

MASA

1 . 8 0 0 . 9 5 0 . 1 1 7 2